

CATIA V5

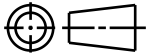

Revision Level		Revision Record	Changed	Date	Approved	Date
Drawing	Part					
03	A	SEE ECN# 012472	CJR	10/09/13	SJA	10/09/13

REFERENCE:

PERFORMANCE REQUIREMENTS AT DRY AS MOLDED:

1. FIR TREE PUSH IN FORCE: 45 NEWTONS (10 LBS) MAX IN EACH APPLICABLE OVAL HOLE SIZE AND A PLATE THICKNESS OF 1.8mm.
2. FIR TREE PULL OUT FORCE: 110 NEWTONS (25 LBS) MIN IN EACH APPLICABLE OVAL HOLE SIZE AND A PLATE THICKNESS OF 1.8mm.
3. SHEET METAL THICKNESS RANGE: 0.60mm - 6.75mm
4. APPLICABLE OVAL HOLE SIZES:
 - A. 6.2 X 12.2mm
 - B. 6.5 X 12.5mm
 - C. 6.5 X 13.0mm
 - D. 7.0 X 12.0mm

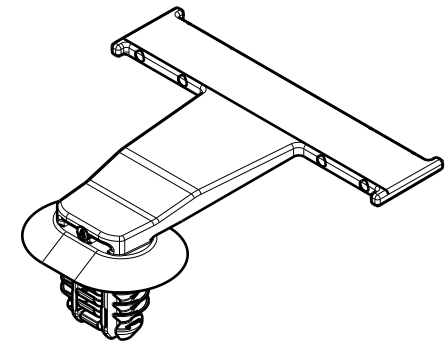
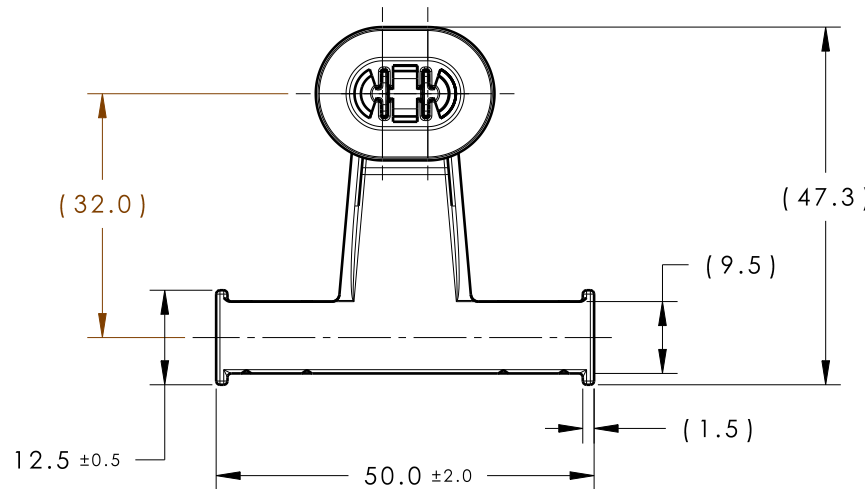
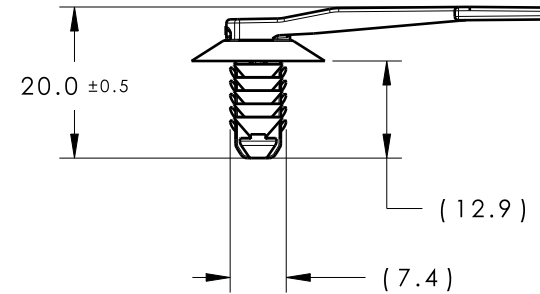
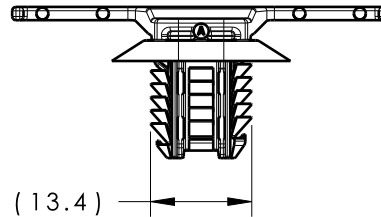

ISOMETRIC VIEW

TYPE NUMBER	MATERIAL	COLOR
SOC12FTOVAL	PA66HIRHS	BLACK
SOC12FTOVAL	PA66HIRHS	NATURAL



Material SEE CHART	Units	millimeters	The copyright of this drawing is reserved by HellermannTyton. It is issued on condition that it is not reproduced, copied or disclosed to a third party, either wholly or in part, without the consent of HellermannTyton.	Drawn	SJA	3/14/12	Article/Type-No SEE CHART	Scale	1:1	
	Tolerance defined on each dimension	Approved		MHT	04/03/13	Title OVAL HOLE TAPE CLIP 32mm OFFSET		Project Number	12-0019	
		HellermannTyton North America Web: www.hellermann.tyton.com			Drawing-No		PRODUCTION : Phase	Format	AH	
					12-0019-001-CSU		Sheet	1/1		